

## Spinner® bike handlebar replacement

### Applies to

Models: Rally and Shift Spinner® belt and chain drive bikes  
 Mfg. Date: Units prior to 06/20/2016

### Issue/Symptoms

The handle bar post may be loose in the frame and wobble. Over time, and with heavy use, handle bar welds may crack.

### Resolution

Replace the handlebar post.

### Tools required

- 2.5 mm hex wrench

### Parts required

QTY	Part Number	Description
1	PPP00FT39031101000	HANDLE BAR POST, ANODIZED

### Procedure - review entire procedure before starting:

- 1 Using a 2.5mm hex wrench, remove the post end caps and stop screws from the existing post (see Figure 1 - six screws total).
- 2 Loosen the handlebar adjustment knob and remove the handle bar assembly (see Figure 2).
- 3 Attach the handlebar assembly to the replacement post and re-install the stop screws and end caps removed in Step 1.
- 4 Install on bike and check for security.



Figure 1

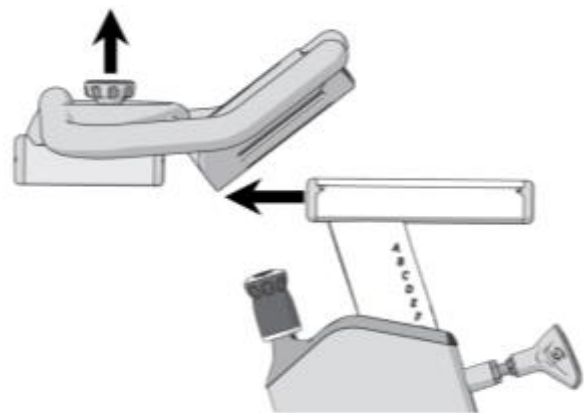

Figure 2